

02 - 07.3

09.11.GB

**Full-lift safety valves with
additional loading
type PV 1509**

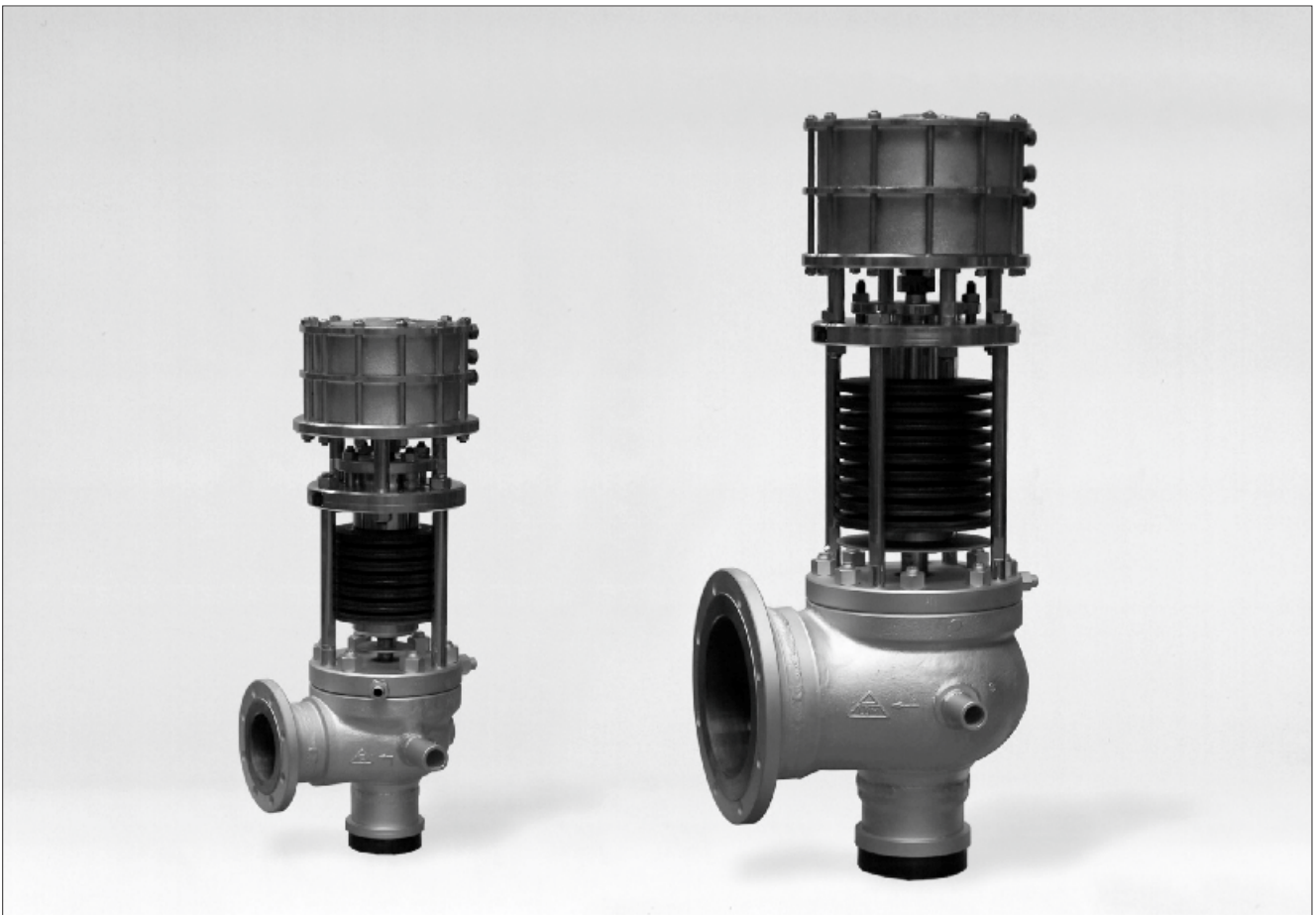

PV 1509

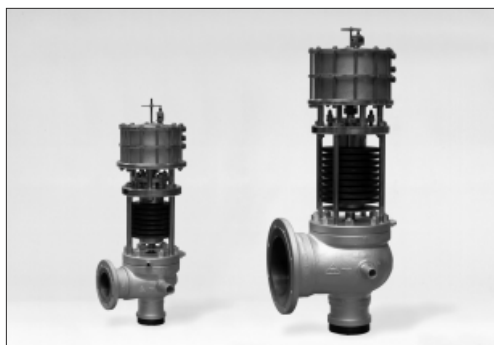

Full-lift safety valves with additional loading DN 65 x 100 to 350 x 600

Application

The full-lift safety valve with additional loading is a valve designed for automatic protection of a pressure equipment (steam boilers, pressure pipelines, steam-conditioning stations, pressure vessels, turbine extraction etc.) against unpermitted pressure increase over allowable limit.

Full-lift safety valve PV 1509 in connection with control unit RP 5330 or RP 5340 according to ČSN EN ISO 4126-5: 2005 (CSPRS).

The valve output guaranteed in accompanying documents is guaranteed only provided that the pressure loss in pipeline does not exceed 3% of opening pressure in inlet pipeline and 25% in outlet pipeline.

The safety valves PV 1509 are designed for water vapour, air, and non-aggressive gases and vapours. The highest temperature of securing medium is up to 620 °C. The valves can operate continuously in dust environment with ambient temperature to 80 °C. After consulting the producer, it is possible to pipe the valve in environment with ambient temperature below zero. The opening pressure range is specified in the "Technical data" table.

The valves are delivered and must be operated together with their accessories, i.e. control unit and aerating system. Single parts can be delivered only in case of the replacement for previously delivered equipment.

Technical data

Valve size DN	Seat values		Opening pressure		Certified flow coefficient
	d [mm]	A [mm ²]	p _{set} [barg]		
			minimal	maximal	K _{dr} [-]
65 x 100	40	1257	160	250	0,84
	46	1662	135	250	
80 x 125	50	1963	122	250	
	56	2463	100	250	
100 x 150	63	3117	90	250	
	70	3848	77	250	
125 x 200	77	4657	72	250	
	85	5675	63	250	
150 x 250	93	6793	54	250	
	98	7543	45	250	
175 x 300	110	9503	38	100	
	117	10751	34	100	
200 x 350	125	12272	29	85	
	140	15394	24	85	
250 x 400	155	18869	20	80	
	168	22167	16	70	
300 x 500	180	25447	13	75	
	200	31416	11	75	
350 x 600	220	38013	10	62,5	0,83
	235	43374	9	55	

A - flow seat section in mm²

d - seat inner diameter in mm

Description

Body is angle, with possibility of either flanges on both ports, or weld ends or combined. Inlet port is of a nozzle type, outlet port is extended. There are welded lugs on the valve body for gripping the valve to the load-bearing structure and absorbing reaction forces. Plug, equipped with an additional flat for achieving of stronger lifting force, is pressed by the means of the spring and pressure air cylinder to the seat. There is a double differential piston moving inside of pressure air cylinder to which the lifting and loading airs are supplied through the hoses from the control unit. The valve is set and adjusted by its producer to the opening pressure specified in the customer's order. Such a setting is secured against an unallowable interference. Dimensions of connection flanges and weld ends are specified after the agreement between the producer and customer when the order is being technically cleared. Standard weld ends correspond to ČSN 13 1075 (3/1991), standard flanges correspond to ČSNEN1092-1 (2/2003) possibly ČSN13 1060. The valves PV 1509 correspond to ČSN EN ISO 4126-5.

Valve function

The safety valve is controlled by its control unit. If the control unit is for any reason put out of service, the valve may be shortly operated just exceptionally or in case of emergency (pressure air supply failure, control unit breakdown etc.). Any longer operation or repeated service in such state may lead to a rapid reduction of the valve service life due to vibrations and leakage.

After reaching the opening pressure value, control unit lets the air out of the space above the piston of pressure air cylinder (loading air) Air pressure from below the plug (lifting air) plus securing medium pressure acting on the plug overcome spring force and safety valve then rapidly opens to its full lift. When the pressure drops, then whole action runs reversed. Rapid opening and closing are just two main preferences of the valves. The valve reaches full opening after the pressure of securing medium increases by max. 3% above the value of set opening pressure (p_{set}). The valve becomes tight closed after the pressure of securing medium drops by max. 5% below the value of set opening pressure (p_{set}).

In case of control air pressure supply failure, the force is induced by the securing medium pressure only. The valve opening runs incomparably more slowly than in the previously described state. As a result of it, the seat is excessively stressed and may get worn. The valve becomes fully open when securing medium increases by max. 5% above the value of set opening pressure. (p_{set}). The valve becomes tight closed when securing medium pressure drops by max. 10% below the value of set opening pressure (p_{set}).

Accessories

Safety valves make an integral equipment together with their accessories consisting of the following:

- control unit type RP 5330 or. RP 5340
- remote signalisation of stroke value

Remote signalisation

Remote signalisation, fixed on the valve body, consists of micro switch and it serves to control the function of safety valve from a distant operating location where it signals "open" and "close" positions. Sensitivity of micro switch enables to register the plug stroke of 0,5 - 1 mm. Remote signalisation can operate in ambient temperature up to 100°C. A cable is never part of the delivery.



Ordering

ČSN 13 3060, section 1, article 5 applies to a certain extent. According to customer's request, producer works out a design for placing the safety valves on securing equipment. Customer must submit all the necessary data. Design contains all the essentials for ordering. Every order is technically cleared and its conclusion is defined in a questionnaire to be confirmed binding by both parties.

Transport and storage

The safety valves including their accessories shall be transported in covered, dry and clean vehicles and other means of transport. They shall be secured against getting damaged by other transported goods. Valves are delivered wrapped separately in PE foil and provided with lathes. Pressure hoses are fixed to the valve body. Control units are wrapped separately in boxes together with their accessories.

The valves shall be stored in dry (max. air humidity of 75%), covered and closed areas with non-aggressive environment. It is recommended to keep the valves in original wrappings. After unwrapping, it is necessary to protect the valve body (spring, needle atc.) as well as control unit from bumping or another damage. Plastic blind flanges are to be removed when installing the valve.

Assembly, maintenance and operation

Instructions for proper assembly of the safety valve into pipeline, its connection to control unit and principles for its operation and maintenance are specified in document PM 087. This document is delivered together with the valve.

Based on our long-time experience, we recommend to carry out inspection and checking of setting the opening pressure periodically once a year. A recommended period for overhaul inspection (checking the state of sealing surface of seat and plug, checking of piston sealing in air cylinder) is every 2 years.

Valve complete specification No. for ordering PV 1509

		XX	XXXX	XXX	/	XXX	-	XXX	XX	/	X	-	XXX,X	/	X	
1. Valve	Safety valve	PV														
2. Series			1509													
3. Nominal size DN	DN-inlet			065												
	DN-outlet					100										
	d-seat							046								
4. Connection	weld / weld										SS					
	weld / flange										SP					
	falnge / flange										PP					
5. Body material	to 400°C												1			
	to 550°C												2			
	to 600°C												3			
6. Opening pressure	barg												175,5			
7. Protected medium	saturated steam															1
	overheated pára															2
	air															3
	other gasses															4

Order example: **PV 1509 065/100 - 046 SS/1 - 175,5/2**

Face to face lengths, dimensions, weights

DN	h_2	h_3	h_4	H	D	S_1	S_2	Weight
	mm	mm	mm	mm	mm	mm	mm	kg
65x100	760	45	55	890	290	275	240	170
80x125	760	45	55	890	290	290	265	190
100x150	850	45	65	995	395	310	270	380
125x200	940	45	65	1085	395	390	330	480
150x250	1050	45	95	1260	500	390	350	650
175x300	1065	45	95	1275	500	420	390	670
200x350	1080	45	95	1290	500	440	420	780
250x400	1160	45	95	1370	500	515	460	980
300x500	1250	45	125	1460	500	590	530	1560
350x600	1400	45	125	1610	500	660	620	1900

Note: Weight, stated in the table, is valid for the valve with weld connection. Tolerance $\pm 10\%$ (based on Belleville spring)
 Heights H, h_2 are variable (± 100 mm) according to Belleville spring

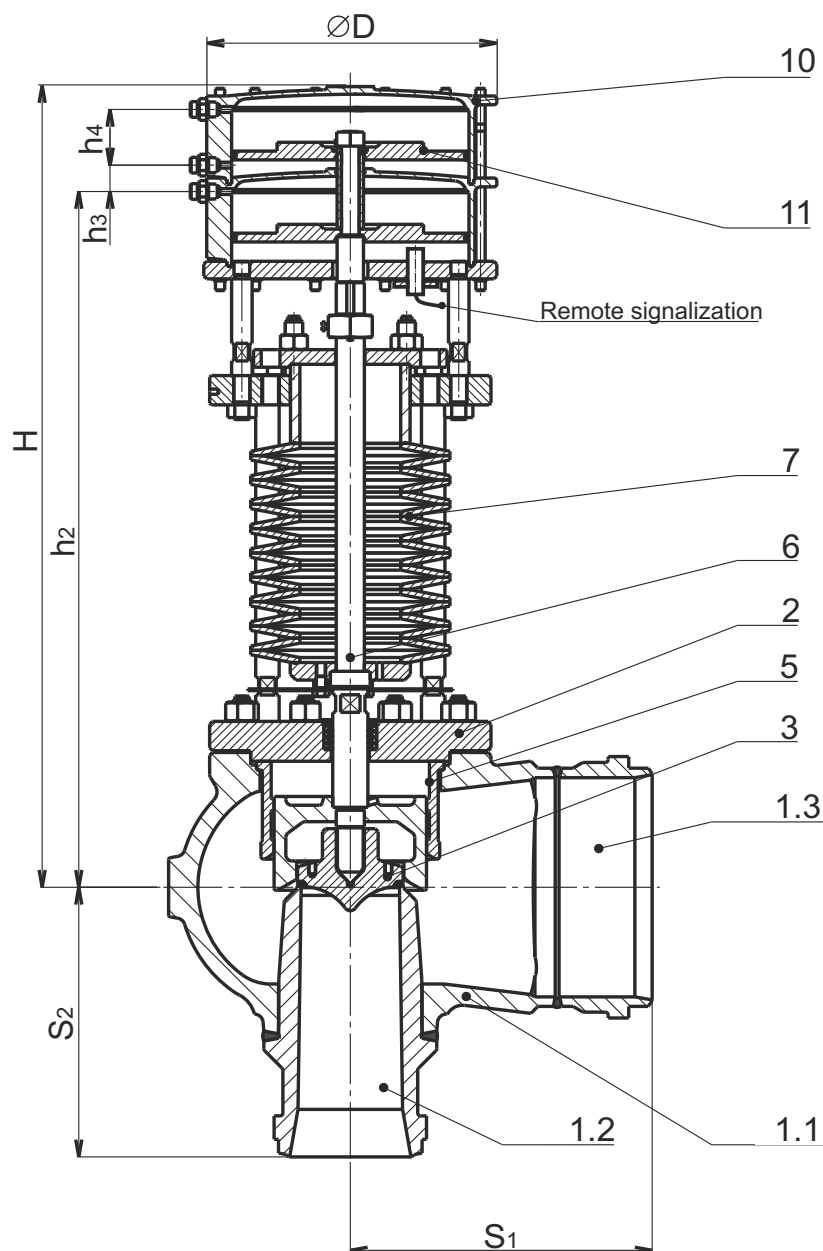

Drain-off piping connection dimensions

DN	A	B	∅C	h1	b	∅d	s
65x100	415	354	51	110	90	26,9	3,2
80x125		354	51		90	26,9	3,2
100x150	520	464	63,5	145	90	26,9	3,2
125x200	530	464	63,5	161	90	26,9	3,2
150x250	610	520	63,5	198	90	26,9	3,2
175x300		520	95		100	26,9	3,2
200x350	750	594	95	218	100	26,9	3,2
250x400	850	594	95	258	100	26,9	3,2
300x500	950	680	127	308	130	26,9	3,2
350x600		680	135			26,9	3,2

Pins for valve fixing and detail of the drainage piping connection

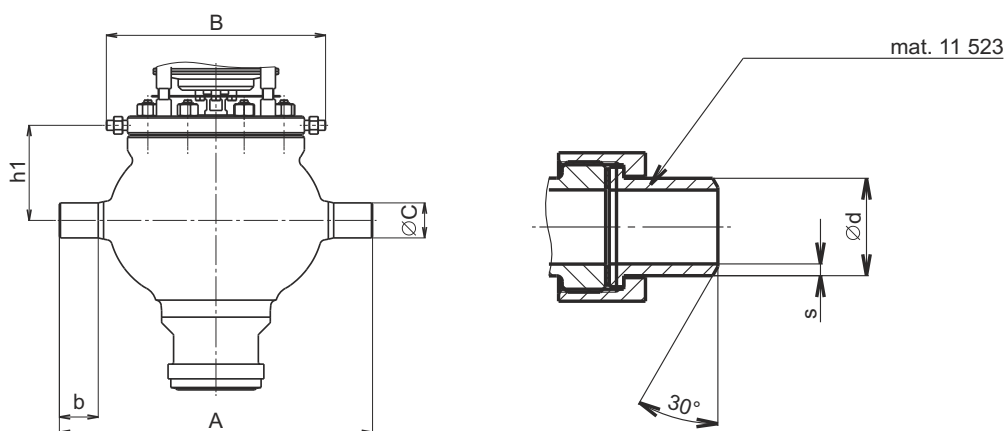

Material of main parts

Position	Name	Material		
		400	550	620
1.1	Seat	1.0619	1.7357	1.4931
1.2	Insertion + Seat weld	1.0426 + Stelit 6	1.7335 + Stelit 6 1.7380 + Stelit 6 1.7383 + Stelit 6	1.4901 + Stelit 6 1.4903 + Stelit 6
1.3	Extension piece	1.0426	1.7335 / 1.7380 / 1.7383	1.4901/1.4903
2	Bonnet	1.0425	1.7335	1.4903/1.7380
3	Plug + Seat weld	1.4923 + Stelit 6 / 1.4922 + Stelit 6		1.4901 + Stelit 6 1.4903 + Stelit 6
5	Plug guide	42 2942.4 / 1.4541		1.4923
6	Needle	1.4122		1.4903/1.4923
7	Disc spring	1.8159		
10	Cylinder	1.7357		
11	Piston	11 523 / 1.0570		



LDM, spol. s r.o.
Litomyšlská 1378
560 02 Česká Třebová
Czech Republic

tel.: +420 465 502 511
fax: +420 465 533 101
E-mail: sale@ldm.cz
<http://www.ldm.cz>

LDM, spol. s r.o.
Office in Prague
Podolská 50
147 01 Praha 4
Czech Republic

tel.: +420 241 087 360
fax: +420 241 087 192

LDM, spol. s r.o.
Office in Ústí nad Labem
Mezní 4
400 11 Ústí nad Labem
Czech Republic

tel.: +420 475 650 260
fax: +420 475 650 263

LDM servis, spol. s r.o.
Litomyšlská 1378
560 02 Česká Třebová
Czech Republic

tel.: +420 465 502 411-3
fax: +420 465 531 010
E-mail: servis@ldm.cz

LDM, Polska Sp. z o.o.
Modelarska 12
40 142 Katowice
Poland

tel.: +48 32 730 56 33
fax: +48 32 730 52 33
mobile: +48 601 354 999
E-mail: ldmpolska@ldm.cz

LDM Bratislava s.r.o.
Mierová 151
821 05 Bratislava
Slovakia

tel.: +421 2 43415027-8
fax: +421 2 43415029
E-mail: ldm@ldm.sk
<http://www.ldm.sk>

LDM - Bulgaria - OOD
z. k. Mladost 1
bl. 42, floor 12, app. 57
1784 Sofia
Bulgaria

tel.: +359 2 9746311
fax: +359 2 9746311
GSM: +359 888 925 766
E-mail: ldm.bg@ldmvalves.net

OOO "LDM Promarmatura"
Moskovskaya street,
h. 21, Office No. 541
141400 Khimki
Russian Federation

tel.: +7 495 777 22 38
fax: +7 495 777 22 38
E-mail: inforus@ldmvalves.com

TOO "LDM"
Lobody 46/2
Office No. 4
100008 Karaganda
Kazakhstan

tel.: +7 7212 566 936
fax: +7 7212 566 936
mobile: +7 701 738 36 79
E-mail: sale@ldm.kz
<http://www.ldm.kz>

LDM Armaturen GmbH
Wupperweg 21
D-51789 Lindlar
Germany

tel.: +49 2266 440333
fax: +49 2266 440372
mobile: +49 177 2960469
E-mail: ldmarmaturen@ldmvalves.com
<http://www.ldmvalves.com>

Your partner